

Behavior of Concrete Slabs Reinforced with FRP Bars, Design and Analysis

Alireza Adimi¹ and Amir Reza Khaloo^{2*}

¹M.Sc Student, Department of Civil Structural Engineering, Sharif University of Technology, International Campus, Kish Island, Iran.

²Professor, Department of Civil Engineering, Sharif University of Technology, Tehran, Iran.

*Corresponding Author:

✉ Khako.am@gmail.com

Received: 15 October, 2022

Accepted: 05 December, 2022

Published: 25 December, 2022

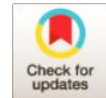

ABSTRACT

In this study, in order to ensure the accuracy of numerical simulations, the numerical 3D simulation of a one-way concrete slab reinforced with tensile fiber-reinforced polymer (FRP) rebars was performed using the finite element Abaqus software. Moreover, the effects of the type of FRP rebars including carbon fiber-reinforced polymer (CFRP) or glass fiber reinforced polymer (GFRP), as well as their amount (depending on the number and diameter of FRP rebars), were evaluated on the vertical load-bearing capacity of the middle of concrete slabs. Moreover, with the 3D numerical simulation of the slab reinforced with tensile and compressive FRP rebars, the effect of using them simultaneously (compared to the use of only FRP rebars) was investigated on the vertical load-bearing capacity at the middle of the slab with respect to the compressive strength of the slab's concrete. Eventually, the slab was numerically simulated reinforced with tensile steel and FRP rebars to study the effect of combining them, compared to the use of only FRP rebars, on the load-bearing capacity at the middle of the slab. The obtained results revealed that the vertical load-bearing capacity of the slab reinforced with tensile CFRP rebars was much higher than that of the one reinforced with tensile GFRP rebars. Moreover, the vertical load-bearing capacity of the concrete slab reinforced with tensile FRP rebars increased with the number and diameter of the tensile FRP rebars. On the other hand, the reduction in the compressive strength of the one-way concrete slab decreased the load-bearing capacity of the concrete slab reinforced with FRP rebars. The simultaneous use of tensile and compressive FRP rebars had no significant effect on increasing the load-bearing capacity of the concrete slabs, especially those with high compressive strengths. Meanwhile, the combination of the tensile steel and FRP rebars increased the vertical load-bearing capacity of the slab.

Keywords: Reinforced concrete slab, FRP rebars, The vertical load-bearing capacity of the slab, Finite element method, Abaqus software

Introduction

The seismic improvement of structures is important and inevitable in Iran, a country located on faults [1]. The uniform failure mode in concrete members reveals the beginning of a mechanism in which both concrete and steel start to buckle, yield, or fail [2]. The ductility is considered from the beginning of the mechanism to the failure of the member and its complete collapse [3]. In other words, the ductility seeks to delay the completion of the mechanism and full failure of the piece. This can be done with respect to the effects of slenderness and fatigue in connections and the efforts

to preserve connections by observing sufficient requirements, including the way to place rebars, stirrups, the position of joints, number, size, bending of stirrups and material type [4].

The use of novel technologies in the seismic improvement of structures is a new approach that should be considered by structural engineers. Given their high strength to weight ratio, strength against corrosion, resistance against fatigue caused by loading, and quick installation, fiber-reinforced polymer (FRP) plates have received considerable attention for the improvement of structures (especially concrete ones) over recent years [1]. Layers with a weight equal to 20%



of the weight of steel have a strength almost two to ten times that of steel, which has led to widespread use of such fibers in various industries [5]. Given the relatively high cost of these fibers in the past, they were rarely used in the construction industry [6]. However, with the wider production of these materials today resulting in their lower production cost, using them has become economical [7]. Furthermore, the novelty of this reinforcement technique leads to widespread studies, which have been conducted on the behavior of these polymers on the flexural reinforcement of concrete columns since the mid-twentieth. The simple execution, along with the high speed of installation, low weight, high tensile strength, resistance against corrosion, and absorption of vibrations, have resulted in the increasing use of this material in the construction industry. These advances have been mainly aimed at improving the mechanical behavior and flexural strength of columns [1].

Reinforced concrete slabs are one of the common horizontal load-carrying members in civil engineering, and widely applied in bridges, ports and hydro-structures [8]. Recently, FRP materials have been extensively used to strengthen existing buildings due to its light weight, fast installation and less invasive approach in comparison with more conventional materials. Design codes have been developed specifically for strengthening buildings using FRP, with ACI440.2R probably being the most widely used standard for the design of FRP strengthening of concrete buildings. However, equations for strengthening concrete diaphragms are not provided in ACI440.2R and, therefore, the equations given for flexural or shear strengthening of other structural members have to be adopted for concrete diaphragm [9]. In recent years, with the development of artificial intelligence, some algorithms with data at the core have emerged [10].

An improved finite difference (FD) procedure to properly estimate the dynamic response of concrete members reinforced with FRP bars under explosion was suggested by Zhou et al. [11]. The obtained results of FD were also compared with those that were obtained by finite element (FE) analysis and single degree of freedom (SDOF) analysis. They reported that the FD procedure is relatively accurate, convenient and applicable to predict the dynamic responses of the flexural concrete members reinforced with FRP bars.

Nigro et al. [12] considered a conceptual approach to fire safety checks for bending moment resistance of FRP reinforced concrete (RC) members. With reference to thermo-mechanical analysis, a simplified design method (for both thermal and mechanical analyses) for sagging bending moment resistance of FRP-RC slabs in fire situations is finally suggested. A shear design equation for concrete beams reinforced with FRP bars was optimized by Shahnewaz et al. [13].

A Genetic Algorithm was applied to optimize the shear equations proposed in FRP design guidelines of ACI440.1R-06, CSA S806-02, CSA S6-09, and Reineck's tooth model. The optimized equation indicated less scatter than the original equations with a significant improvement in coefficient of variation (CoV) with the validation database, in comparison with the original ones.

In order to accurately predict the bond strength of CFRP-steel (CS), efficient data-driven models were developed through implementing ensemble learning (EL) algorithms named by "gradient boosting decision tree (GBDT)" and "random forest (RF)" as two representative ones on a collected CS single-shear test database. These models' performances on bond strength prediction were compared and also three representative machine learning algorithms "artificial neural network (ANN)", "support vector machine (SVM)" and "classification and regression tree (CART)" are utilized for validating the necessity. The comparison results indicate that the model generated by the GBDT algorithm attains the best accuracy for CS interfacial bond strength prediction ($R^2 = 0.98$) among the ensemble and machine learning algorithms [14]. Among these algorithms, machine learning has received remarkable attention of researchers, and there have been many successful examples [14, 15]. Hoang et al. [16] presented the development of an ensemble machine learning model to predict the punching shear resistance of R/C interior slabs. Mangalathu et al. [17] build an explainable machine learning model to predict the punching shear strength of flat slabs without transverse reinforcement. In addition, some researchers [18, 19] even use the atomistic simulations as the input parameters of machine learning to predict the performance of materials and structures, which has also seen success.

Despite extensive studies on the behavior of reinforced concrete slabs, especially those reinforced with steel rebars, no comprehensive studies have been conducted on the behavior of concrete slabs reinforced with FRP rebars. Therefore, there are some ambiguities regarding the tensile and compressive behavior of these rebars in the load-bearing capacity of reinforced concrete slabs (depending on their amount in the slab and their combination with steel rebars). Furthermore, as there lacks adequate information regarding the use of different codes to design concrete slabs reinforced with FRP bars and analyze various behaviors of them, the present study focuses on how available standards can effectively be implemented to design and analyze the structural behavior of concrete slabs. The two following goals will be investigated:

1. To assess the use of various codes in evaluating the structural, flexural and shear behaviors of concrete slabs reinforced with FRP bars

2. To provide rational approach for design and analysis of slabs reinforced with FRP bars

Materials and Method

The materials of the three types of reinforcements used in this program are GFRP, CFRP, and steel. The GFRP rods are manufactured by pultrusion of E-glass continuous fibers and thermosetting polyester resin. To enhance the bond characteristics, the surface is wrapped by helically glass fiber strands and covered by

a mixture of a known grain size of sand and polyester resin. The CFRP bars are fabricated using continuous coal tar pitch-based continuous fibers and epoxy resin[20].

Experimental program

The eight-prototype one-way concrete slabs, reinforced by three different reinforcement materials, tested in this program are given in Table 1.

Table 1
Process and results of parametric studies

Bar Type	Max. Load (KN)	
	GFRP	CFRP
	71	162
D (mm)	9.5	44
	12.7	56
	15.9	71
N	4	62
	5	71
	6	79
Bar Application	Tensile	21
	f_c (MPa)	31
		63
Bar Application	Tensile +	21
	Compressive	31
	f_c (MPa)	63
Bar Composition	GFRP	71
	GFRP + Steel	85

They included five samples that were strengthened by GFRP rebars, two by common steel rebars and one by CFRP rebars. The three slabs reinforced by CFRP and steel reinforcements are used as control specimens to compare the behavior of the slabs reinforced by GFRP bars shown in Fig. 1[20]. The length and width of all the slabs were 3500 mm (11.5 ft) and 1000 mm (3.28 ft), respectively, with a clear span of 3000 mm (10 ft), which was kept constant throughout the study. The two thicknesses of slabs were 150 mm (6 in.) and 200 mm (8 in.) according to the requirements of the

Canadian Design Code, CAN3-A23.3-M94.9. A concrete cover of 38 mm (1.5 in.) was used for the longitudinal reinforcements. This was accomplished by using reinforcement ratios less, equal, and more than the balanced reinforcement ratio P_b for the slabs, respectively. After completion of testing the 150 mm (6 in.) thick slabs, the program was revised for reasons related to the observed modes of failure, which will be discussed later. A 1000 kN closed-loop MTS actuator was used to apply the load through a spreader beam system [20].

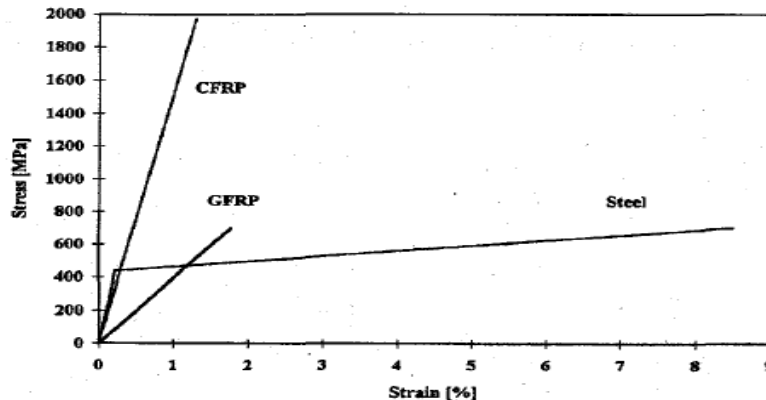

Figure 1. Material characteristics of the GFRP, CFRP, and steel reinforcements [20]

Modeling of the loading of experimental samples

In order to model the uniform loading of experimental samples and achieve the vertical force on the middle of samples during the loading, a given vertical

displacement was applied to the middle of the top surface of samples (with an area of $350 \times 350 \text{ mm}^2$) (Figures 2 and 3) [20].

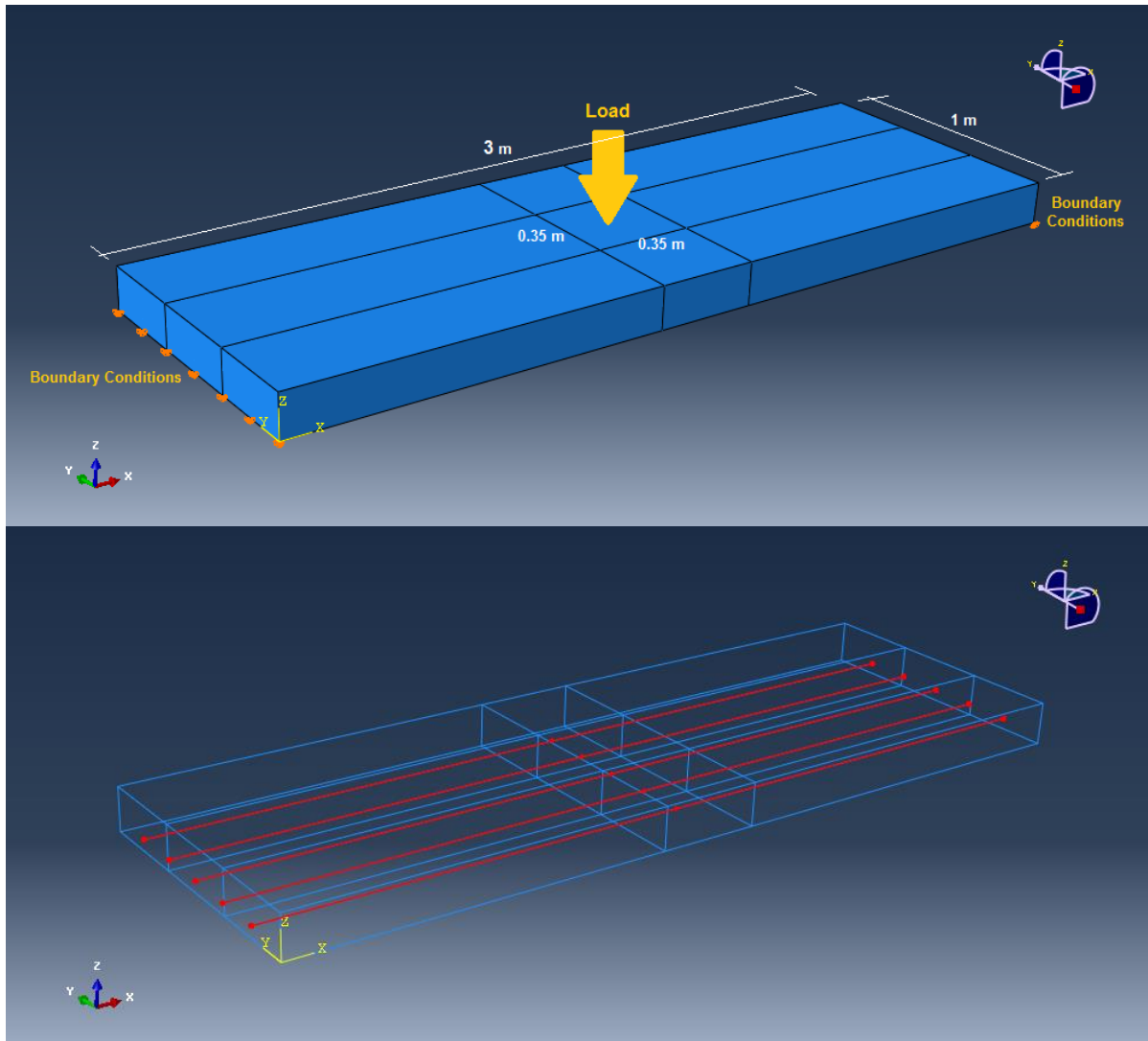

Figure 2. Geometric model of the experimental samples [21]

Meshing of the experimental samples

To mesh the concrete mass in the one-way slab of the numerical models, the continuous 3D 8-node elements with reduced integration (named C3D8R in the Abaqus

software) were used [21]. Meanwhile, the 3D linear structural beam elements (called B31 in the Abaqus software) [22] were used to mesh the rebars.

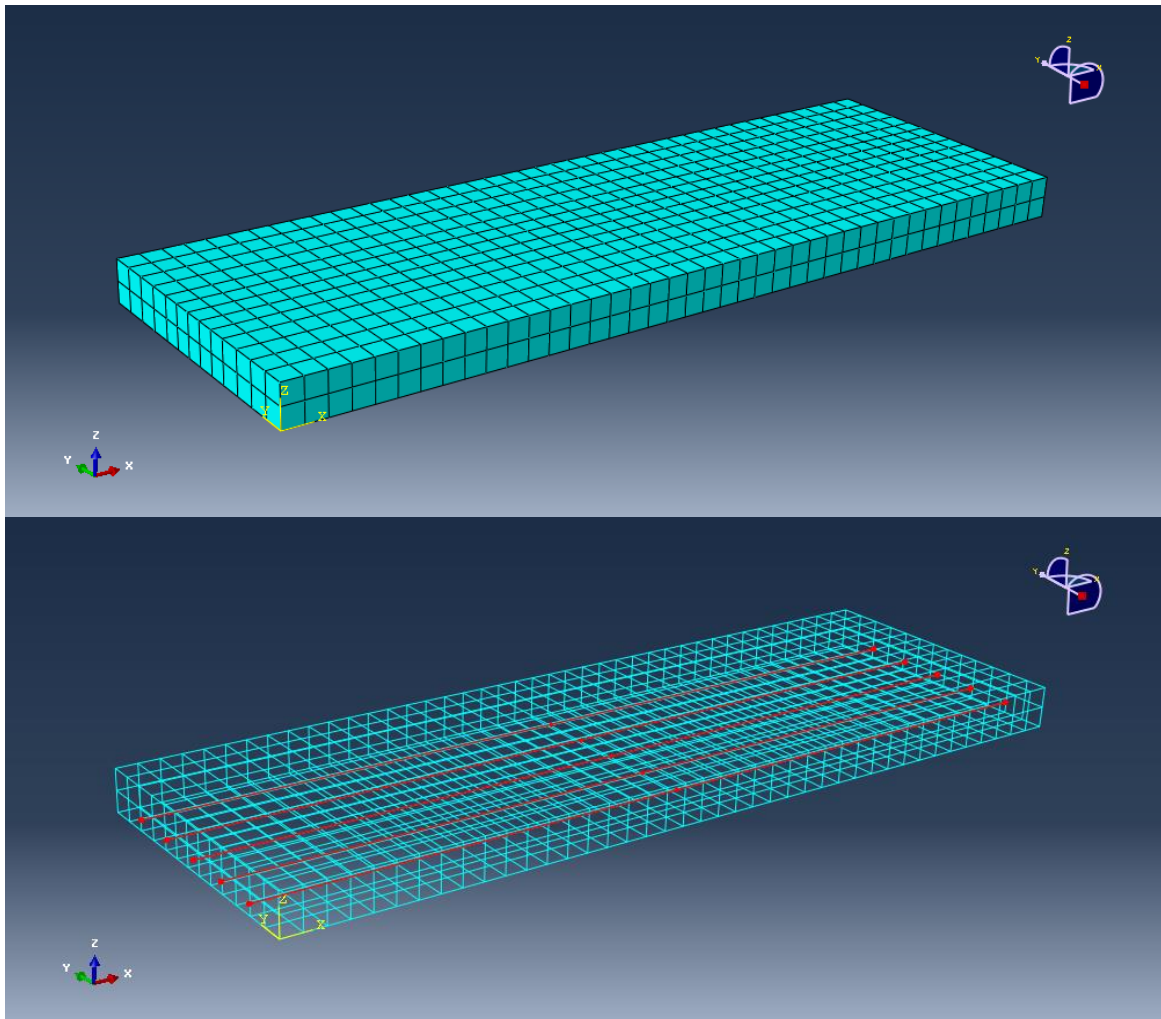

Figure 3. The general meshing of the experimental samples [21]

Evaluation and validation of the results obtained from numerical simulation of experimental samples

To ensure the accuracy of the numerical simulation methods and the software used for this purpose in this

research, the vertical force applied to the middle of the experimental samples while applying the defined uniform vertical displacement, was evaluated and matched with the force measured in the test.

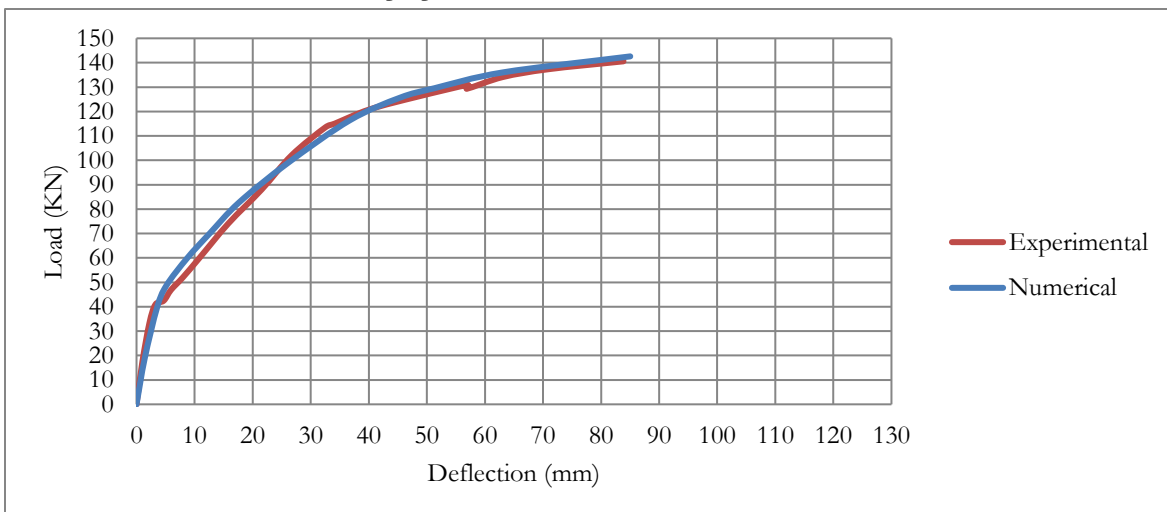

Figure 4. The vertical displacement-vertical force curve at the middle of the sample S-150-T during the test [23] and 3D numerical simulation

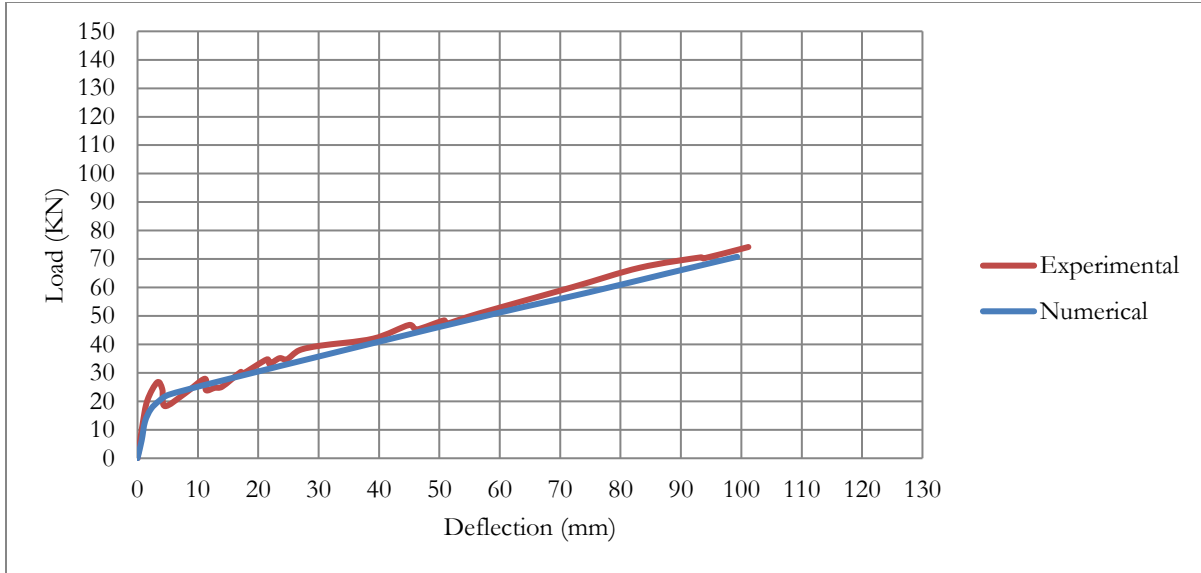

Figure 5. The vertical displacement-vertical force curve at the middle of the sample I-150-C during the test [23] and 3D numerical simulation

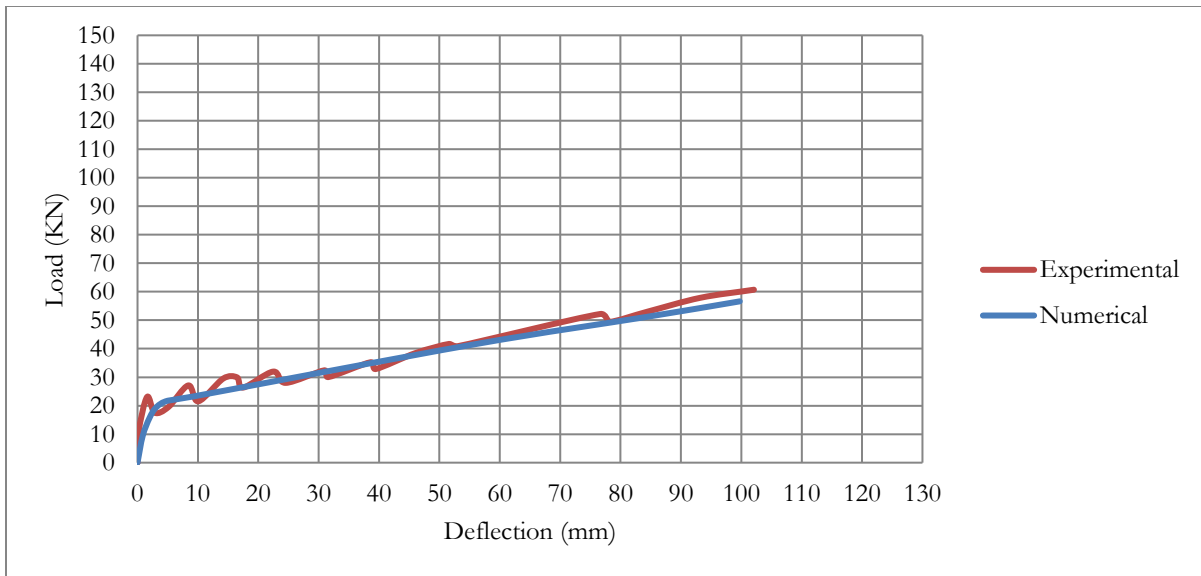

Figure 6. The vertical displacement-vertical force curve at the middle of the sample I-150-A during the test [23] and 3D numerical simulation

Figures 5 to 10 indicate the good agreement between the value and trend of the vertical force at the middle of the samples while applying the determined vertical displacement to the samples with force measured in the test. This reveals the accuracy of the numerical simulations and the software used for this purpose in the research. In this research, the effect of the type of FRP rebars (CFRP or GFRP), as well as their amount (their diameter and number), on the load-bearing capacity at the middle of the slabs during the uniform vertical loading was assessed. The effect of using both tensile and compressive GFRP rebars simultaneously (regarding the compressive strength of the slab's

concrete) on the vertical load-bearing capacity at the middle of slabs was evaluated and compared with the case using only tensile GFRP rebars (at different values of concrete's compressive strength). Finally, the effect of combining steel and GFRP rebars on the load-bearing capacity of the slab was investigated and compared with the mode only using GFRP rebars. The Abaqus software was used for 3D numerical simulations, in which the properties of the experimental samples studied by Michaluk et al. [20] were used. The implicit analytical procedure was used in the simulations. In order for the numerical modeling of the one-way concrete slab, a homogenous and

isotropic concrete mass was used with a 3 m in length (along the x-axis), 1 mm in width (along the y-axis), and a thickness of 0.07 m (along the z-axis) [23], as well as an elastoplastic hybrid plastic-failure constitutive model to define the plastic behavior (and properties according to the desired compressive strength).

To evaluate the numerical modeling of the steel rebars in the one-way concrete slab, structural members (beams) buried in concrete with a diameter of 15 mm [24], a perfect elastoplastic constitutive model (with elastic behavior of steel until reaching the yield stress), as well as a density, elastic modulus, Poisson's ratio, yield stress, and ultimate stress of 78.5 kN/m³, 177000 MPa, 0.3, 435 MPa, and 700 MPa, respectively [24] were employed (Fig. 11).

For the numerical modeling of the transverse GFRP rebars in the one-way concrete slab, structural members (beams), buried in concrete with a hybrid elastic-failure constitutive model, as well as a density, elastic modulus, Poisson's ratio, and tensile strength of 21 kN/m³, 41300 MPa, 0.22, and 690 MPa, respectively [24] were performed.

To assess the numerical modeling of the CFRP rebars in the one-way concrete slab, structural members (beams) buried in concrete having a hybrid elastic-failure constitutive model, a density, elastic modulus, Poisson's ratio, and tensile strength of 17.9 kN/m³, 147000 MPa, 0.22, and 1970 MPa, respectively [24] were assumed.

Modeling of the boundary conditions in the reinforced concrete slab

In order for the stability of the numerical models, the transitional displacements on the two sides of the slab (along transverse direction) were constrained [24].

Modeling of the loading on the reinforced concrete slab

To model the vertical uniform loading of the reinforced concrete slab and achieve the vertical load-bearing capacity on the slab during the loading, a given vertical displacement (0.1 m) was applied to the middle of the top surface of the slab (with an area of 350 × 350 mm²) [24].

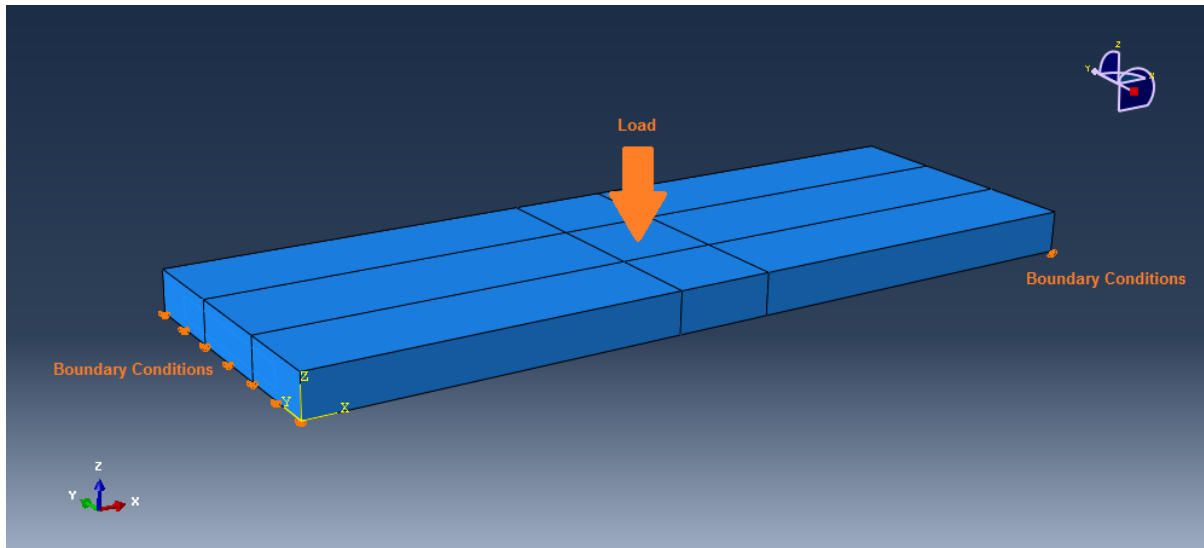

Figure 7. The geometric model of the concrete slab reinforced with tensile rebars

Results and Discussion

Effect of the type of FRP rebars on the load-bearing capacity of concrete slabs reinforced with FRP rebars

In this section, the middle vertical load-bearing capacity (and its maximum obtained from the vertical displacement - middle vertical loading) of the one-way concrete slab in two conditions, reinforced with tensile

GFRP and CFRP rebars, is evaluated and compared (Figures 13 and 14). In this case, the diameter and number of both kinds of the FRP rebars were 15.9 mm and five, respectively. The compressive strength of the slab's concrete was 63 MPa.

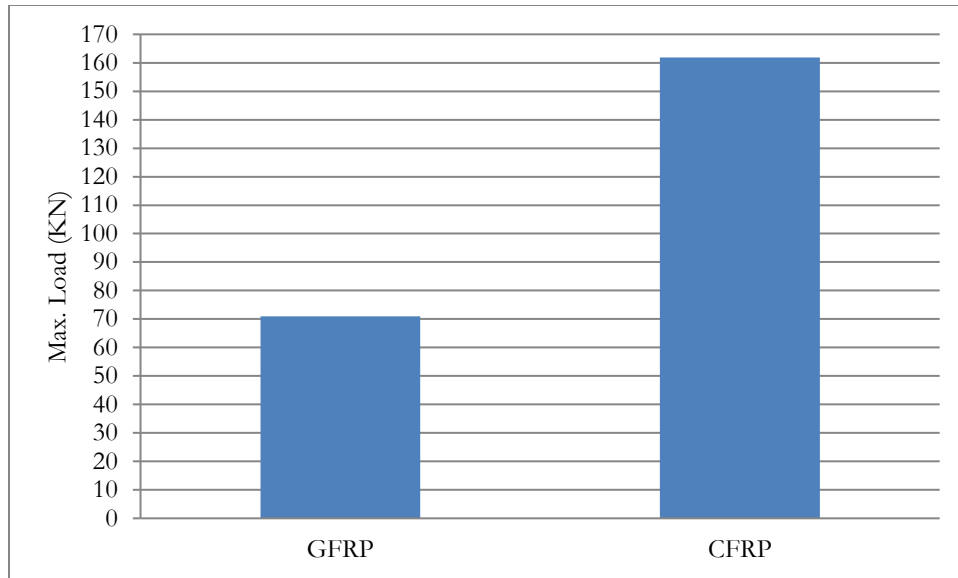

Figure 8. Effect of the type of FRP rebars on the maximum load-bearing capacity of the middle of concrete slabs reinforced with FRP rebars

Figures 7 and 8 indicate that during the uniform vertical loading on the middle of the one-way concrete slab, the vertical load-bearing of the slab reinforced with tensile CFRP rebars was much more than that of the one reinforced with tensile GFRP rebars. The reason is that the tensile CFRP rebars have much higher stiffness and strength compared to the tensile GFRP rebars, which results in the remarkable increase in the stiffness and tensile strength of the one-way concrete slab reinforced with tensile CFRP rebars (compared to the one reinforced with tensile GFRP rebars).

On the other hand, the figures reveal that the concrete slab reinforced with tensile FRP rebars had great stiffness at vertical displacements up to a certain value (vertical yield displacement) (especially in the case reinforced with tensile CFRP rebars). However, at higher displacements, as the plastic strains and cracks of the slab's concrete emerged, the stiffness, and finally, the vertical load-bearing growth, reduced. The reduction in the vertical load-bearing growth was much lower in the case reinforced with tensile CFRP rebars (compared to the case reinforced with tensile GFRP rebars), indicating much lower vertical ductility of the CFRP-reinforced concrete slab, or in other words, the more brittle performance of the tensile CFRP rebars (compared to the tensile GFRP rebars) in the concrete

slab. The reason is that FRP is a material with an elastic-failure behavior whose stress-strain curve is almost linear until the failure. This results in the brittleness of the FRP rebars (compared to the steel rebars with elastoplastic behavior), and consequently, the lower ductility of concrete slabs reinforced with such rebars. The presence of carbon fibers in FRP, i.e., CFRP (compared to the presence of glass fibers in FRP, i.e., GFRP) led to more brittle behavior of tensile CFRP rebars (compared to the tensile GFRP rebars) in the concrete slab.

Effect of the amount of FRP rebars on the load-bearing capacity of concrete slabs

In this section, the vertical load-bearing of the middle of the reinforced concrete slab (and its maximum on the vertical displacement – vertical load-bearing) are evaluated and compared in the two following modes:

The first mode is that the change in the diameter of the GFRP rebars (d) from 9.5 to 15.9 mm in the concrete slab. In this mode, the number of GFRP rebars was five. The compressive strength of the concrete was also 63 MPa.

The second mode is that the change in the number of the GFRP rebars (N) from 4 to 6 in the concrete slab. The diameter of the GFRP rebars was 15.9 mm. The compressive strength of the concrete was also 63 MPa.

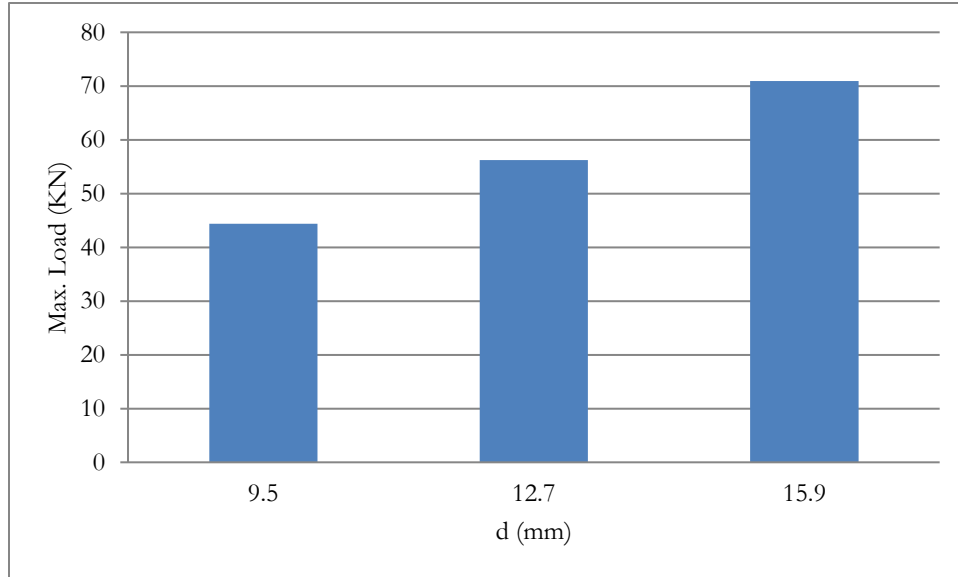

Figure 9. The effect of the diameter of FRP rebars on the maximum vertical load bearing at the middle of the concrete slabs

Figures 15 and 16 show that as the tensile FRP rebars became thicker (especially at diameters of more than 12.7 mm), the vertical load-bearing of the slabs increased. The thicker FRP rebars had higher stiffness and tensile strength, resulting in the higher stiffness and tensile strength of the concrete reinforced with them. Accordingly, the reduction in the vertical load-bearing of the concrete slab (reinforced with tensile FRP

rebars), occurring at displacements higher than the vertical yield displacement and with the emergence of the plastic strains and concrete cracks, also decreased with the rise in the diameter of tensile FRP rebars (especially from 12.7 mm), indicating the reduced ductility of the slab (reinforced with FRP rebars) or more brittle performance of the tensile CFRP rebars at larger diameters.

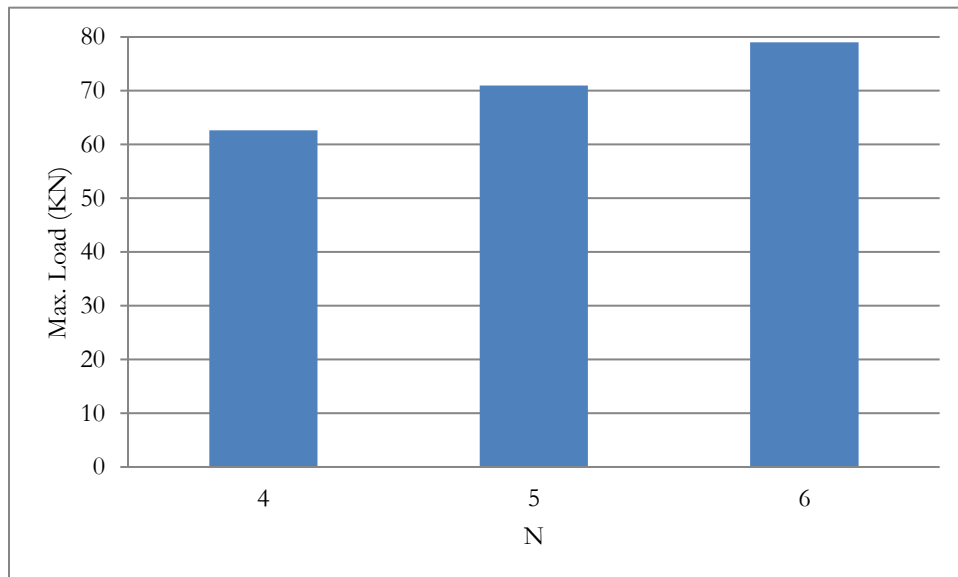

Figure 10. The effect of the number of FRP rebars on the maximum vertical load bearing at the middle of concrete slabs

Figures 9 and 10 demonstrate that the load-bearing of the concrete slab increased with the number of the tensile FRP rebars due to the higher stiffness and

tensile strength. Accordingly, the reduced growth of the vertical load-bearing of the concrete slab (reinforced with tensile FRP rebars) at displacements higher than

the vertical yield displacement and with the emergence of plastic strains, and finally, concrete cracks, also decreased with the rise in the number of tensile FRP rebars, indicating the reduced vertical ductility of the slab (reinforced with FRP rebars) or more brittle performance of the tensile CFRP rebars with the rise in the number of rebars.

The cross-impact of the compressive strength of the concrete and compressive FRP rebars on the load-bearing of concrete slabs reinforced with FRP rebars

In this section, by changing the compressive strength of the concrete (f_c) from 21 to 63 MPa, the vertical load-bearing of the middle of the reinforced concrete slab (and its maximum on the vertical displacement - vertical load-bearing curve) are evaluated and compared in two cases, i.e., reinforced with tensile GFRP rebars and reinforced with tensile and compressive GFRP rebars. In this case, the diameter and number of both tensile and compressive GFRP rebars were 15.9 mm and five, respectively.

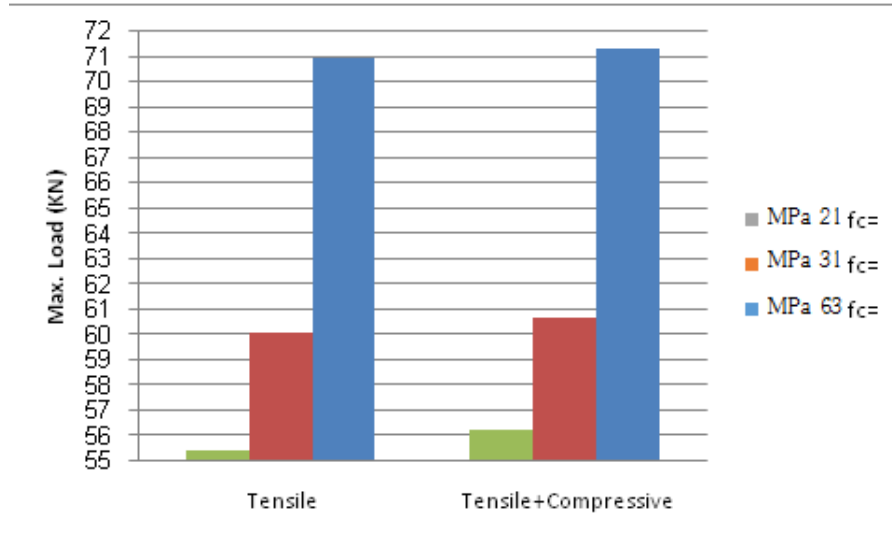

Figure 11. The effect of using both tensile and compressive FRP rebars (depending on the compressive strength of concrete) on the maximum vertical load bearing at the middle of the concrete slabs

Figures 20 to 23 show that the vertical load-bearing of the concrete slab reinforced with FRP rebars increased with the compressive strength of the one-way slab (especially from 31 MPa). The reason is that the higher compressive strength of concrete increases the stiffness of the slab reinforced with FRP rebars. Accordingly, the growth reduction of the vertical load-bearing of the concrete slab (reinforced with FRP rebars) at displacements higher than the vertical yield displacement and with the emergence of plastic strains, and finally, concrete cracks, also decreased with the rise in the compressive strength of the concrete (especially from 31 MPa), indicating the reduced vertical ductility of the slab (reinforced with FRP rebars) or its more brittle performance with the rise in the compressive strength.

On the other hand, the figures reveal that the simultaneous use of tensile and compressive FRP rebars (compared to the use of only tensile FRP rebars) had no significant effect on increasing the load-bearing

of the concrete slab, especially the one with high compressive strength (63 MPa). The reason is that the rise in the compressive strength of the concrete reduced the compressive weakness of the concrete slab reinforced with FRP rebars and eliminated the need for compressive FRP rebars, along with tensile ones.

The effect of combining steel and FRP rebars on the load-bearing of concrete slabs

In this section, the vertical load-bearing at the middle of the one-way concrete slab (and its maximum on the vertical displacement-vertical load-bearing curve) in two modes, reinforced only with tensile GFRP rebars and reinforced with two tensile steel rebars and three tensile GFRP rebars) are evaluated and compared. In this case, the diameter and number of both types of rebars (steel and GFRP) were 15.9 mm and five, respectively. The compressive strength of the concrete was 63 MPa.

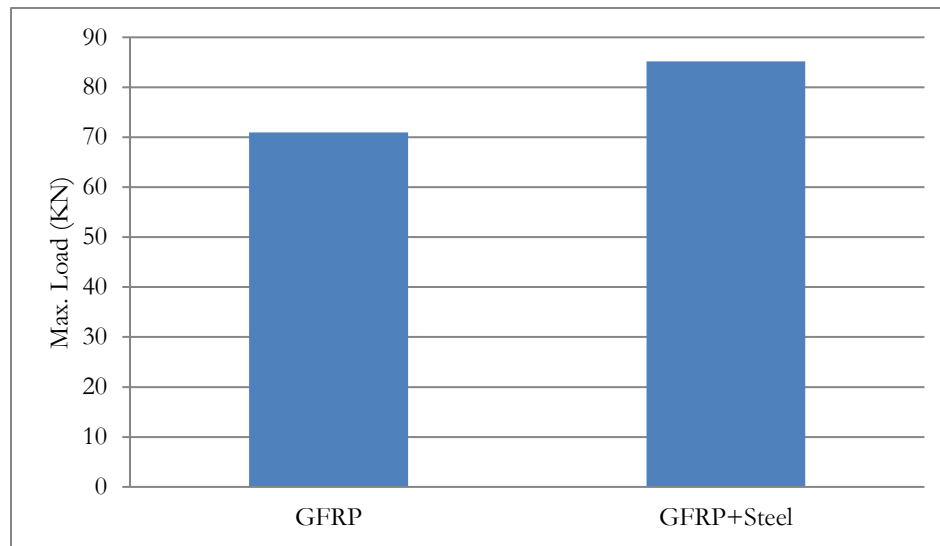

Figure 12. The effect of combining steel and FRP rebars on the maximum vertical load bearing at the middle of the reinforced concrete slabs

As shown in Figures 11 and 12, combining the tensile steel and FRP rebars (compared to the use of only tensile FRP rebars), raised the vertical load-bearing of the reinforced concrete slab. The reason is that compared to FRP rebars, the steel rebars have higher stiffness and plastic resistance, leading to the increased vertical load-bearing of the concrete slab reinforced with tensile steel rebars (along with tensile FRP rebars). On the other hand, the figures show that the reduction in the vertical load-bearing of the concrete slab reinforced with tensile steel and FRP rebars (occurring after the vertical yield displacement and the emergence of plastic strains, and finally, concrete cracks) increased compared to the reduction in the load-bearing of the concrete slab reinforced with only tensile FRP rebars. This indicated the higher ductility of the vertical concrete slab reinforced with tensile steel and FRP rebars, or in other words, the softer performance of the slab by using the combination of tensile steel and FRP rebars. As mentioned, the reason is that FRP is a material with an elastic-failure behavior whose stress-strain curve is almost linear until the failure. This results in the brittleness of the FRP rebars (compared to the steel rebars with elastoplastic behavior), and consequently, the lower ductility of concrete slabs reinforced with only such rebars.

Conclusion

The evaluation and comparison of the vertical load-bearing capacities at the middle of one-way concrete slabs reinforced with tensile GFRP rebars, tensile CFRP rebars, tensile and compressive GFRP rebars, and tensile steel and GFRP rebars revealed that:

- During the uniform vertical loading on the middle of the one-way concrete slab, the vertical load-bearing of the slab reinforced with tensile CFRP rebars was much

more than that of the one reinforced with tensile GFRP rebars.

- The tensile CFRP rebars had much higher stiffness and strength than the tensile GFRP rebars, resulting in the remarkable increase in the stiffness and tensile strength of the one-way concrete slab reinforced with tensile CFRP rebars. The concrete slab reinforced with tensile FRP rebars had great stiffness at vertical displacements up to a certain value. However, at higher displacements, as the plastic strains and cracks of the slab's concrete emerge, the stiffness, and finally, the vertical load-bearing growth reduced. The reduction in the vertical load-bearing growth was much lower in the case reinforced with tensile CFRP rebars, indicating much lower vertical ductility of the CFRP-reinforced concrete slab, or in other words, the more brittle performance of the tensile CFRP rebars in the concrete slab.

- The presence of carbon fibers in FRP, i.e., CFRP, led to more brittle behavior of tensile CFRP rebars in the concrete slab.

- The thicker tensile FRP rebars raised the stiffness and tensile strength of the rebars, resulting in the higher stiffness and tensile strength of the concrete slab reinforced with them.

- The reduction in the vertical load-bearing of the concrete, occurring at displacements higher than the vertical yield displacement and with the emergence of the plastic strains and concrete cracks, also decreased with the rise in the diameter of tensile FRP rebars indicating the reduced ductility of the slab or more brittle performance of the tensile CFRP rebars at larger diameters.

- The larger number of tensile FRP rebars raised the stiffness and tensile strength of the concrete slab reinforced with them.

According to the conducted study, the following suggestions can be provided for future studies:

- Numerical evaluation of the effect of FRP rebars on the load-bearing of concrete slabs with openings
- Numerical evaluation of the effect of the types of FRP rebars on the explosive behavior of concrete slabs.

References

1. Neves RLP, et al. Post-harvesting silvicultural treatments in canopy logging gaps: medium-term responses of commercial tree species under tending and enrichment planting. *Forest Ecol Manag.* 2019; 451: 117521.
2. Jiang C, et al. Failure mode-based calculation method for bending bearing capacities of normal cross-sections of corroded reinforced concrete beams. *Eng Struct.* 2022; 258: 114113.
3. Ma H, et al. Failure mechanism and design method of reticulated shells considering joint damage accumulation effect under earthquake load. in *Structures.* Elsevier. 2022.
4. Christensen RM. Mechanisms and measures for the ductility of materials failure. *Proceedings of the Royal Society A.* 2020; 476(2239): 20190719.
5. Fallah-Valukolae S, Hashemi S, Nematzadeh M. Effect of steel fiber on flexural performance of bilayer concrete beams with steel and GFRP rebars: Experiments and predictions. Elsevier. *Struct.* 2022.
6. Fu B, et al. Concrete reinforced with macro fibres recycled from waste GFRP. *Construct Build Mater.* 2021; 310: 125063.
7. Reichenbach S, et al. A review on embedded fibre-reinforced polymer reinforcement in structural concrete in Europe. *Construct Build Mater.* 2021; 307: 124946.
8. Shen Y, Sun J, Liang S. Interpretable machine learning models for punching shear strength estimation of FRP reinforced concrete slabs. *Crystal.* 2022; 12(2): 259.
9. Law R, et al. Ecological information from spatial patterns of plants: insights from point process theory. *J Ecol.* 2009; 97(4): 616-628.
10. Geetha N, Bridjesh P. Overview of machine learning and its adaptability in mechanical engineering. *Materials Today: Proceedings*, 2020.
11. Zhou Y, et al. Improved finite difference analysis of dynamic responses of concrete members reinforced

with FRP bars under explosion. *Compos Struct.* 2019; 230: 111518.

12. Nigro E, et al. Guidelines for flexural resistance of FRP reinforced concrete slabs and beams in fire. *Compos B Eng.* 2014; 58: 103-112.
13. Shahnewaz M, et al. Optimized shear design equation for slender concrete beams reinforced with FRP bars and stirrups using genetic algorithm and reliability analysis. *Eng Struct.* 2016; 107: 151-165.
14. Chen SZ, et al. Development of data-driven prediction model for CFRP-steel bond strength by implementing ensemble learning algorithms. *Construct Build Mater.* 2021; 303: 124470.
15. Mangalathu S, et al. Machine-learning interpretability techniques for seismic performance assessment of infrastructure systems. *Eng Struct.* 2022; 250: 112883.
16. Nguyen HD, Truong GT, Shin M. Development of extreme gradient boosting model for prediction of punching shear resistance of r/c interior slabs. *Eng Struct.* 2021; 235: 112067.
17. Mangalathu S, et al. Explainable machine learning models for punching shear strength estimation of flat slabs without transverse reinforcement. *J Build Eng.* 2021; 39: 102300.
18. Rahman A, et al. A machine learning framework for predicting the shear strength of carbon nanotube-polymer interfaces based on molecular dynamics simulation data. *Compos Sci Tech.* 2021; 207: 108627.
19. Ilawe NV, Zimmerman JA, Wong BM. Breaking badly: DFT-D2 gives sizeable errors for tensile strengths in palladium-hydride solids. *J Chem Theory Comput.* 2015; 11(11): 5426-5435.
20. Michaluk CR, et al. Flexural behavior of one-way concrete slabs reinforced by fiber reinforced plastic reinforcements. *Struct J.* 1998; 95(3): 353-365.
21. Abaqus Users Manual V. 6.10-1. Dassault Systemes Simulia Corp. Providence, RI, 2011.
22. Sheil D, Burslem DF, Alder D. The interpretation and misinterpretation of mortality rate measures. *J Ecol.* 1995; 331-333.
23. Rocha FR, et al. Multicommutation in flow analysis: concepts, applications and trends. *Anal Chim Act.* 2002; 468(1): 119-131.
24. Park R, Paulay T. Reinforced Concrete Structures, John Wiley & Sons. NY, USA, 1975.

SJFST

Copyright: © 2022 The Author(s); This is an open-access article distributed under the terms of the Creative Commons Attribution License (<http://creativecommons.org/licenses/by/4.0>), which permits unrestricted use, distribution, and reproduction in any medium, provided the original work is properly cited.

Citation: Adimi A, Khaloo AR. Behavior of Concrete Slabs Reinforced with FRP Bars, Design and Analysis. *SJFST*, 2022; 4(4): 1-12.

<https://doi.org/10.47176/sjfst.4.4.1>